

**MOD. D**

转换触点压力开关 - 内螺纹  
Pressure switch with SPDT contacts - female case

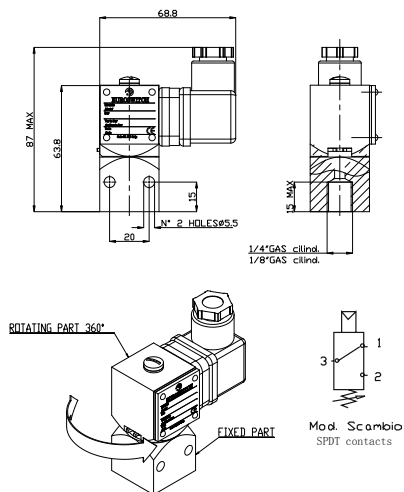

本体	阳极化铝
安装螺纹	碳钢镀锌 (或不锈钢)
电压负载	250Vac
电流负载	5(1)A
最高耐温	80 -120°C(取决于膜片)
动作方式	1B
环境污染	正常
机械寿命	10 <sup>6</sup> 次 (膜片) 10 <sup>5</sup> 次 (活塞)
防护等级	IP 65
延迟	设定值的15%
<input type="checkbox"/> 膜片形式 (见附页)	
	1 NBR-2 FKM (标准) -3EPDMCH-4 CR-5Silicon-6 HNBR
<input type="checkbox"/> O-密封 (见附页)	
	7 PUR - 9NBR
重量	265 g

• Case	Anodized aluminium
• Threaded fitting	Zinc plated steel (on request stainless steel)
• Max switched voltage	250 Vac
• Max switched current	5 (1) A
• Max fluid temperature	80° to 120°C depending on diaphragm
• Action type	1B
• Pollution situation	normal
• Mechanical working life	10 <sup>6</sup> diaphragm version 10 <sup>5</sup> piston version
• Protection degree	IP65
• Hysteresis	~15% of setting value
• <input type="checkbox"/> Insert diaphragm code (see page 86):	
	1 NBR - 2 FKM (standard) - 3 EPDM CH - 4 CR - 5 Silicon - 6 HNBR
• <input type="checkbox"/> Insert O-Ring code for piston version (see page 86):	
	7 PUR- 9 NBR
• Weight	~ 265 gr

Grounding must be fasten by assembling system

Codice - Part Number		螺纹 - thread	设定范围 Setting range bar	延迟 20° C Tolerance at 20° C bar	最高耐压 Static pressure max bar
膜片 diaphragm	24F 2 0 1 <input type="checkbox"/> 1	1/8" gas	0.2 - 5	±0.1	100
	24F 2 0 G <input type="checkbox"/> 1	1/4" gas			
	24F 2 0 1 <input type="checkbox"/> 2	1/8" gas			
	24F 2 0 G <input type="checkbox"/> 2	1/4" gas			
	24F 2 0 1 <input type="checkbox"/> 3	1/8" gas	1 - 10	±0.3	150
	24F 2 0 G <input type="checkbox"/> 3	1/4" gas			
	24F 2 0 1 <input type="checkbox"/> 4	1/8" gas			
	24F 2 0 G <input type="checkbox"/> 4	1/4" gas			
活塞 piston	24F 2 0 1 <input type="checkbox"/> 5	1/8" gas	30 - 150	± 7	500
	24F 2 0 G <input type="checkbox"/> 5	1/4" gas			
	24F 2 0 1 <input type="checkbox"/> 6	1/8" gas	100 - 300	± 10	
	24F 2 0 G <input type="checkbox"/> 6	1/4" gas			