

**MOD.
P540**

水平安装液位开关
Electromagnetic level sensor lateral fixing

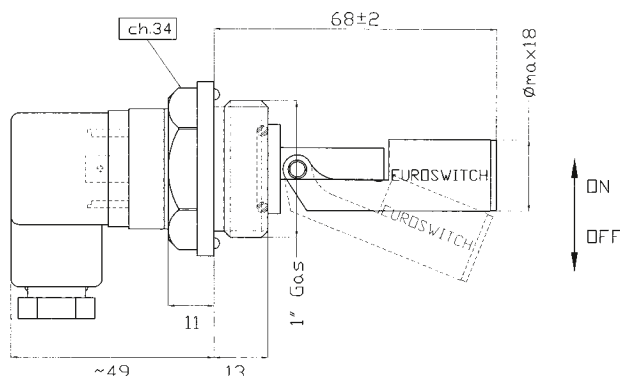

使用介质	矿物油-柴油-汽油
安装	1 G 阳极化铝
浮球	尼龙
O-密封	NBR
电气连接	DIN 43650插头
连接方式	NO/NC
最大功率负载	40W(3W SPDT)
最大电流负载	1A(0.25A SPDT)
最大电压负载	<50V
动作方式	1B
环境污染	正常
流体比重	>0.85
工作温度	-10℃/+100℃
防护等级	IP 65
重量	100 g

• Use	Mineral Oils - Diesel fuel - Petrol
• Fixing	1" Aluminum Anodized
• Float	Nylon
• O-Ring	NBR
• Electrical connection	Connector DIN 43650
• Type of contact	Reed N.O./ N.C. (SPDT)
• Max switch. capacity	40 W (3 W SPDT)
• Max switch. current	1 A (0,25 A SPDT)
• Max switch. voltage	< 50 V
• Action type	1B
• Pollution situation	normal
• Fluid specific weight	> 0,85
• Working temperature	-10°C / +100°C
• Protection degree	IP65
• Weight	~ gr 100

订货号 - Part Number	
<p>P540F8 - 100</p> <p>常开，常闭可以通过转动开关互换 The contact can be converted from N.C. to N.O. by rotating the sensor upside down</p>	<p>P540F8 - 580</p> <p>SPDT 触点 SPDT Contact</p>